



3-Phase LoRaWAN DIN Energy Meter



The PMC-350-C 3-Phase DIN Energy Meter is CET's latest offer for the wireless IoT energy metering market using the LoRaWAN technology for its Long-Range wireless communication capability. Housed in a standard DIN form factor measuring 72x70x95mm, it is perfectly suited for extremely space restricting environment. With a standard RS-485 port and Modbus RTU protocol support, IEC 62053-22 Class 0.5S and IEC 62053-21 Class 1 compliance for 5A Input and SCCT/SCCTA Input respectively as well as optional support for LoRaWAN AS923-1/2/3/4, KR920, AU915 or EU868, it becomes a vital component of an intelligent, distributed and IoT based EMS. The PMC-350-C optionally provides 4xDI for Status Monitoring, 2xRO for Control and Alarming or 2xSS Pulse Output for Energy Pulsing as well as 2 or 4xRTD and 1xResidual Input for Temperature and Leakage Current measurements, respectively.

Typical Applications

- Industrial, Commercial and Utility Substation Metering
- Building, Factory and Process Automation
- Sub-metering and Cost Allocation
- Energy Management and Power Quality Monitoring
- LoRaWAN Class A/C at AS923-1/2/3/4, KR920, AU915 or EU868

Features Summary

Ease of use

- Easy installation with DIN-Rail mounting, no tools required
- Support LoRaWAN Class C Node that offers the lowest latency for Server to End-Node communication
- Simple commissioning and low-deployment cost with Split-Core CT and wireless IoT communication

Basic Measurements

- ULN, ULL per Phase and Average
- Current per Phase and Average with calculated Neutral
- kW, kvar, kVA per Phase and Total
- PF per Phase and Total
- 3-phase Total and per-phase kWh, kvarh Import/Export/Net/Total and kVAh Total
- Frequency
- Device Operating Time (Running Hours)
- Optional Temperature and Residual Current measurements
- Optional DI for Status Monitoring and Utility Pulse Counting

Enhanced Measurements

- U and I THD, TOHD, TEHD and Individual Harmonics up to 31st
- Current TDD, TDD Odd, TDD Even, K-Factor and Crest Factor
- U and I Unbalance and Phase Angles
- Fundamental kW and PF
- 3-phase Total and per-phase kvarh Q1-Q4
- Demands, Predicted Demands and Max. Demands for kW/kvar/kVA Total and per Phase Current with Timestamp for This Month and Last Month (or Since Last Reset and Before Last Reset)

Multi-Tariff TOU

- Two TOU schedules, each providing
 - 12 Seasons
 - 20 Daily Profiles, each with 12 Periods in 0-60 min configurable interval
 - 90 Holidays or Alternate Days
 - 8 Tariffs, each providing the following information
 - 3-phase Total and per-phase kWh/kvarh Import/Export, kVAh Total
 - kW/kvar/kVA Max. Demands

Setpoints

- 10 user programmable Setpoints with extensive list of monitoring parameters including Voltage, Current, Power and THD, etc.
- Configurable thresholds, time delays and DO triggers

Max./Min. Log

- Max./Min. Log with Timestamp for Real-time measurements such as Voltage, Current, In, Freq., kW, kvar, kVA, PF, Unbalance, K-Factor, Crest Factor and THD
- Configurable for This Month/Last Month or Before/Since Last Reset

SOE Log

- 100 events time-stamped to ± 1 ms resolution
- Setup changes, Setpoint, DI status changes, DO operations, Clear Actions, Residual and Temperature Alarm, etc.

Monthly Energy Log

- 12 monthly recording of kWh, kvarh Import/Export/Total/Net, kVAh, kvarh Q1-Q4 as well as kWh/kvarh Import/Export and kVAh per Tariff

Daily/Monthly Freeze Log

- Daily/Monthly Log with Timestamps for kWh, kvarh, kVAh Total and Max. Demands for kW, kvar, kVA Total
- Available through Modbus and LoRaWAN communications for 60 Daily Freeze records (2 months) and 36 Monthly Freeze records (3 years)

Data Recorder

- 5 Data Recorders of 16 parameters each for Real-time measurements, Harmonics, Energy, Demand, TOU, Pulse Counters, etc.
- Recording interval from 1 minute to 40 days

Diagnostics

- Frequency Out-of-Range, Loss of Voltage/Current
- kW Direction per Phase and Total, Possible incorrect CT Polarity
- Incorrect U & I Phase Sequence

Communications

- Optically isolated RS-485 port at 1,200 to 38,400 bps
- Modbus RTU protocol
- Optional LoRaWAN support at AS923-1/2/3/4, KR920, AU915 and EU868 for IoT applications

Autonomous Data Push with the LoRaWAN option

- DevEUI (End-Device Identifier), AppEUI (Application Identifier) and AppKey (AES-128 key) for OTAA activation
- User selectable Auto-Push Data Packages of Real-time measurements, 3-phase Total and per-phase Energy, Demands, Harmonics, Max./Min. Logs, Freeze Logs, I/O and Setpoint status can be autonomously pushed to the LoRaWAN Network Server in configurable interval

*Not all measurements are available via the wireless LoRaWAN option.

System Integration

- Supported by our PecStar® iEMS and PMC Setup
- Easy integration into other Automation or SCADA systems via Modbus RTU protocol or IoT based Energy Management System via LoRaWAN

I/O Options

- 4xDI + 2xDO (Mechanical Relay)
- 4xDI + 2xSS Pulse Output
- 4xRTD + 1xResidual Input*
- 2xRTD + 1xResidual Input + 2xSS Pulse Output*

*PT100 sensor & Residual CT not included

Front Panel Display

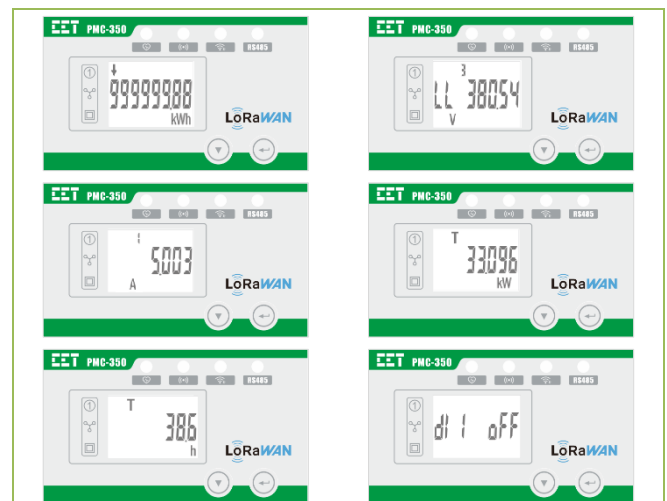

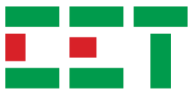

3-Phase LoRaWAN DIN Energy Meter

Technical Specifications

Voltage Inputs (V1, V2, V3, VN)		
Voltage (Un)	277ULN/480ULL	
Range	20-277V L-N/35-480V L-L	
Burden	<2W/phase	
Input Impedance	5MΩ	
Permanent Overload	750VAC L-L	
Frequency	45-65Hz	
Current Inputs (-I11, I12, -I21, I22, -I31, I32)		
Current (In)	SCCT Option	SCCTA Option
	40mA	2mA
Range	0.15%-100% In	0.1%-120% In
Starting Current	0.15% In	0.1% In
Burden	<0.25VA per phase	<0.25VA per phase
External SCCTs	50A/40mA, 100A/40mA, 200A/40mA, 400A/40mA, 800A/40mA, 1600A/40mA	5A/2mA
Optional (In)	5A	
Range	5mA-6A	
Power Supply (L/+, N/-)		
Standard	95-250VAC/DC, ±10%, 47-440Hz	
Optional	95-480VAC/DC, ±10%, 47-440Hz	
Burden	<2W	
Overvoltage Category	OVC III up to 300ULN	
Optional Digital Inputs (DI1, DI2, DI3, DI4, DIC)		
Type	Dry contact, 24VDC internally wetted	
Sampling	1000Hz	
Hysteresis	1ms minimum	
Optional Digital Outputs (DO11, DO12, DO21, DO22)		
Type	Form A Mechanical Relay	
Loading	5A @ 250VAC or 30VDC	
Optional RTD Temperature Inputs (TC1, TC2, TC3, TC4)		
RTD Type	2-Wire PT100 (sensor not included)	
PT100	-40-200°C	
Alarm Range	45-140°C	
Optional Residual Current Inputs (-IR, IR)		
Range	20mA-2000mA	
Optional Solid State Energy Pulse Output (E1+, E1-, E2+, E2-) Selectable kWh/kvarh		
Pulse Constant	10/100/1000/3200 imp/kxh	
Isolation	Optical	
Max. Load Voltage	80V	
Max. Forward Current	50mA	
Pulse Width	80±20ms	
Communications		
RS-485 (Standard)	Modbus RTU	
Protocol	1200/2400/4800/9600/19200/38400 bps	
Baud Rate	LoRaWAN® Specification 1.0.3	
LoRaWAN (Optional)	Class A/C Compliance	
ISM Bands (Optional)	Applicable to the following regions:	
AS923-1	Australia, New Zealand, Malaysia, Hong Kong, Singapore, Taiwan, Thailand, Cambodia, etc.	
AS923-2	Vietnam, Indonesia	
AS923-3	Denmark, Norway, Saudi Arabia, etc.	
AS923-4	Israel	
KR920	South Korea	
AU915	Australia, New Zealand, Argentina, Anguilla, Brazil	
EU868	Europe, United Arab Emirates, etc.	
Environmental Conditions		
Operating Temp.	-25°C to +70°C	
Storage Temp.	-40°C to +85°C	
Humidity	5% to 95% non-condensing	
Atmospheric Pressure	70 kPa to 106 kPa	
Pollution Degree	2	
Mechanical Characteristics		
Mounting	DIN Rail or optional Panel Mount	
Unit Dimensions	72x70x95mm	
Panel Cutout	78x67mm	
IP Rating	IP30	

Standards of Compliance

Safety Requirements	
CE LVD 2014 / 35 / EU	EN 61010-1: 2010 EN 61010-2-030: 2010
Electrical Safety in Low Voltage Distribution Systems up to 1000Vac and 1500 Vdc	IEC 61557-12: 2018 (PMD)
Insulation AC Voltage: 2kV @ 1 minute Insulation Resistance: >100MΩ Impulse Voltage: 6kV, 1.2/50µs	IEC 62052-31: 2015
Electromagnetic Compatibility CE EMC Directive 2014 / 30 / EU (EN 61326: 2013)	
Immunity Tests	
Electrostatic Discharge	EN 61000-4-2: 2009
Radiated Fields	EN 61000-4-3: 2006+A1: 2008+A2: 2010
Fast Transients	EN 61000-4-4: 2012
Surges	EN 61000-4-5: 2014+A1: 2017
Conducted Disturbances	EN 61000-4-6: 2014
Magnetic Fields	EN 61000-4-8: 2010
Voltage Dips and Interruptions	EN 61000-4-11: 2004+A1: 2017
Ring Wave	EN 61000-4-12: 2017
Emission Tests	
Limits and Methods of Measurement of Electromagnetic Disturbance Characteristics of Industrial, Scientific and Medical (ISM) Radio-Frequency Equipment	EN 55011: 2016
Limits and Methods of measurement of Radio Disturbance Characteristics of Information Technology Equipment	EN 55032: 2015
Limits for Harmonic Current Emissions for Equipment with Rated Current ≤16 A	EN 61000-3-2: 2014
Limitation of Voltage Fluctuations and Flicker in Low-Voltage Supply Systems for Equipment with Rated Current ≤16 A	EN 61000-3-3: 2013
Emission Standard for Residential, Commercial and Light-Industrial Environments	EN 61000-6-4: 2007+A1: 2011
RED (Radio Equipment Directive)	
Assessment of Electronic and Electrical Equipment Related to Human Exposure Restrictions for Electromagnetic Fields (0Hz - 300 GHz)	EN/IEC 62311: 2020
Short Range Devices (SRD) Operating in the Frequency Range 25 MHz to 1000MHz	ETSI EN 300 220-1 V3.1.1: 2017 ETSI EN 300 220-2 V3.1.1: 2017
Audio/Video, Information and Communication Technology Equipment - Part 1: Safety Requirements	IEC 62368-1: 2018
Mechanical Tests	
Spring Hammer Test	IEC 62052-31: 2015
Vibration Test	IEC 62052-11: 2020
Shock Test	IEC 62052-11: 2020

Accuracy

Parameters	Accuracy		Resolution
	SCCT/SCCTA	5A CT Input	
Voltage	±0.5%	±0.2%	0.01V
Current	±0.5%	±0.2%	0.001A
kW, kvar, kVA	±1.0%	±0.5%	0.001kX
kWh, kVAh	IEC 62053-21: 2020 Class 1	IEC 62053-22: 2020 Class 0.5S	0.01kXh
kvarh	IEC 62053-23: 2020 Class 2 IEC 62053-24: 2020 Class 1	IEC 62053-23: 2020 Class 2 IEC 62053-24: 2020 Class 0.5S	0.01kvarh
PF	±1.0%	±0.5%	0.001
Frequency	±0.02Hz		0.01Hz
In (Cal.)	±1.0%		0.001A
THD	IEC 61000-4-7 Class II		0.001%
Iresidual	±1.0%		0.1mA
Temperature	±1°C		0.1°C



Ordering Information

Terminals Diagram

Product Code	Description
PMC-350 3-Phase LoRaWAN DIN Energy Meter	
Basic Function	
C	Multifunction Measurements, LCD Display, 1xRS-485
Input Current	
5*	5A (Class 0.5S)
SCCT	40mA Input for use with 50A/40mA, 100A/40mA, 200A/40mA, 400A/40mA, 800A/40mA or 1600A/40mA SCCTs (SCCTs not included)
SCCTA	2mA Input for use with 5A/2mA SCCT (SCCTs not included)
Input Voltage	
5	277ULN/480ULL + 20% (1P2W ULN, 1P2W ULL, 1P3W, 3P3W, 3P4W, Demo)
Power Supply	
2	95-250 VAC/VDC, 47-440Hz
4*	95-480 VAC/VDC, 47-440Hz
Frequency	
5	45-65Hz
Expansion 1*	
N	None
A	4xDI + 2xDO (Mechanical Relay)
B	4xDI + 2xSS Pulse Output
Expansion 2*	
N	None
T	4xRTD + 1xResidual Input
X*	2xRTD + 1xResidual Input + 2xSS Pulse Output
Expansion Communication*	
N	None
1	LoRaWAN @ EU868 with External Antenna
4	LoRaWAN @ AU915 with Internal Antenna
5	LoRaWAN @ AU915 with External Antenna
6	LoRaWAN @ AS923-1/2/3/4 with Internal Antenna
7	LoRaWAN @ AS923-1/2/3/4 with External Antenna
9	LoRaWAN @ KR920 with External Antenna
Language	
E	English
PMC-350 - C SCCT 5 2 5 N 7 E	PMC-350-CSCCT525NN7E (Standard Model)

* Additional charges apply
 * Input Current "5" is only available with Power Supply "4" + Expansion 1 "N" + Expansion 2 "X". Expansion Communication options are unrestricted.
 * Power Supply "4" is only available with Expansion 1 "N" + Expansion 2 "X". Input Current options and Expansion Communication options are unrestricted.
 * Expansion 2 "X" is only available with Power Supply "4" + Expansion 1 "N". Input Current options and Expansion Communication options are unrestricted.

PMC-350-C SCCT/SCCTA Models
(4xDI+2xDO+4xRTD+1xIr+1xRS-485)

A	Voltage Inputs	E	Current Inputs
B	2xDigital Output	F (3-10)	4xRTD Input
C	Power Supply	G	1xRS-485 Port
D (1, 2)	1xIr Input	H	4xDigital Input

PMC-350-C 5A Current Input Model
(2xRTD+1xIr+2xSS Pulse Output+1xRS-485)

A	Voltage Inputs	E	Current Inputs
B	Power Supply	F (7-10)	2xSS Pulse Output
C (1, 2)	1xIr Input	G	1xRS-485 Port
D (3-6)	2xRTD Input		

Dimensions and Installations

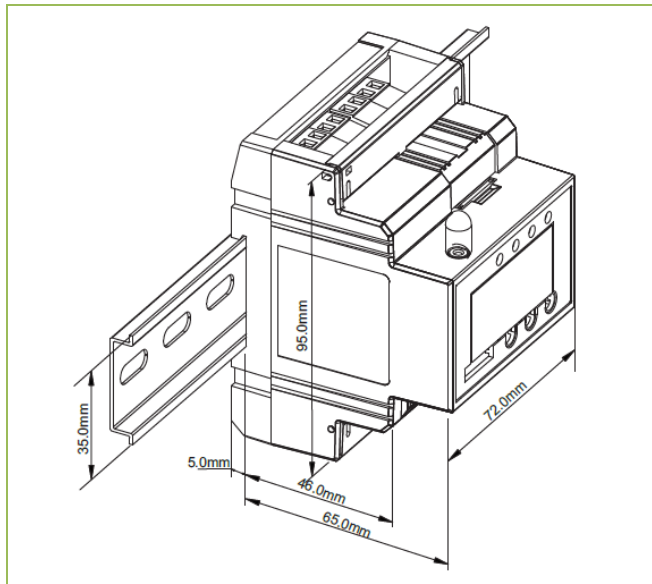

CET Electric Technology Inc.

E: sales@cet-global.com

W: www.cet-global.com

Your Local Representative

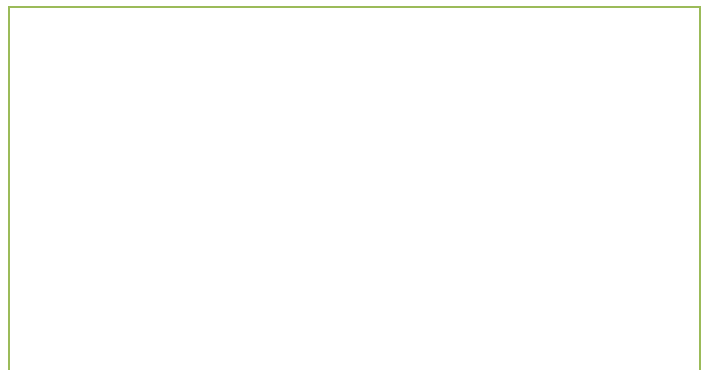

Revision Date: December 18, 2023